

MODELS:

SRW12US33 / SRW12US33G

SmartRack® Wall-Mount Rack Enclosure Cabinets

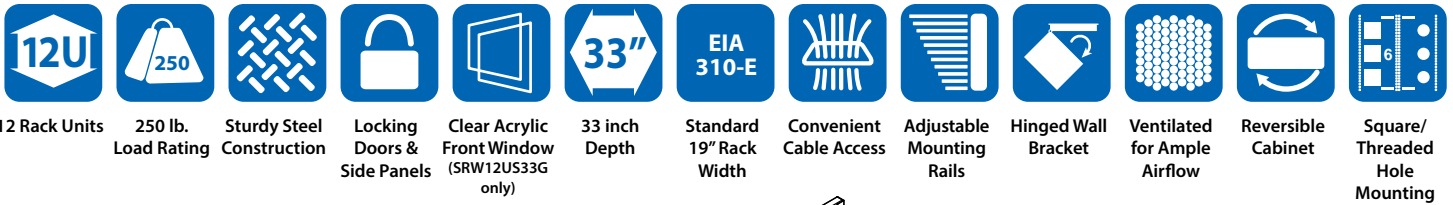

- A** Front Door
(Lockable/Removable/Reversible. SRW12US33 door is perforated; SRW12US33G door has a clear acrylic window.)
- B** Adjustable Mounting Rails (4)
(Support square and threaded hole mounting options.)
- C** Side Panels (2)
(Lockable/Removable)
- D** Hinged Wall Bracket
(Lockable/Reversible. Allows the cabinet to swing away from the wall for convenient rear access to equipment and cabling.)
- E** Cable Access Port Covers (4)
(Removable)
- F** Ventilation Fan Ports (4)
(Support optional SRFANWM fan kit.)
- G** Keys (2)

Also Includes: Owner's Manual, cabinet ground screw, pre-installed front door ground wire and rackmount equipment mounting hardware (36 M6 cage nuts, 36 M6 mounting screws, 36 M6 nylon cup washers and 36 12-24 screws).

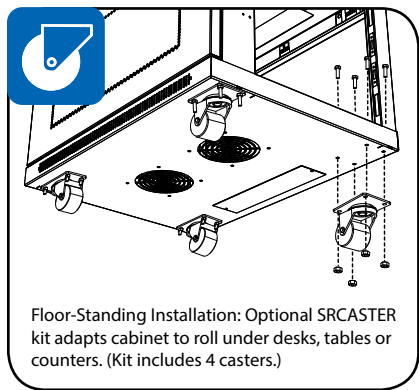

Floor-Standing Installation: Optional SRCASTER kit adapts cabinet to roll under desks, tables or counters. (Kit includes 4 casters.)

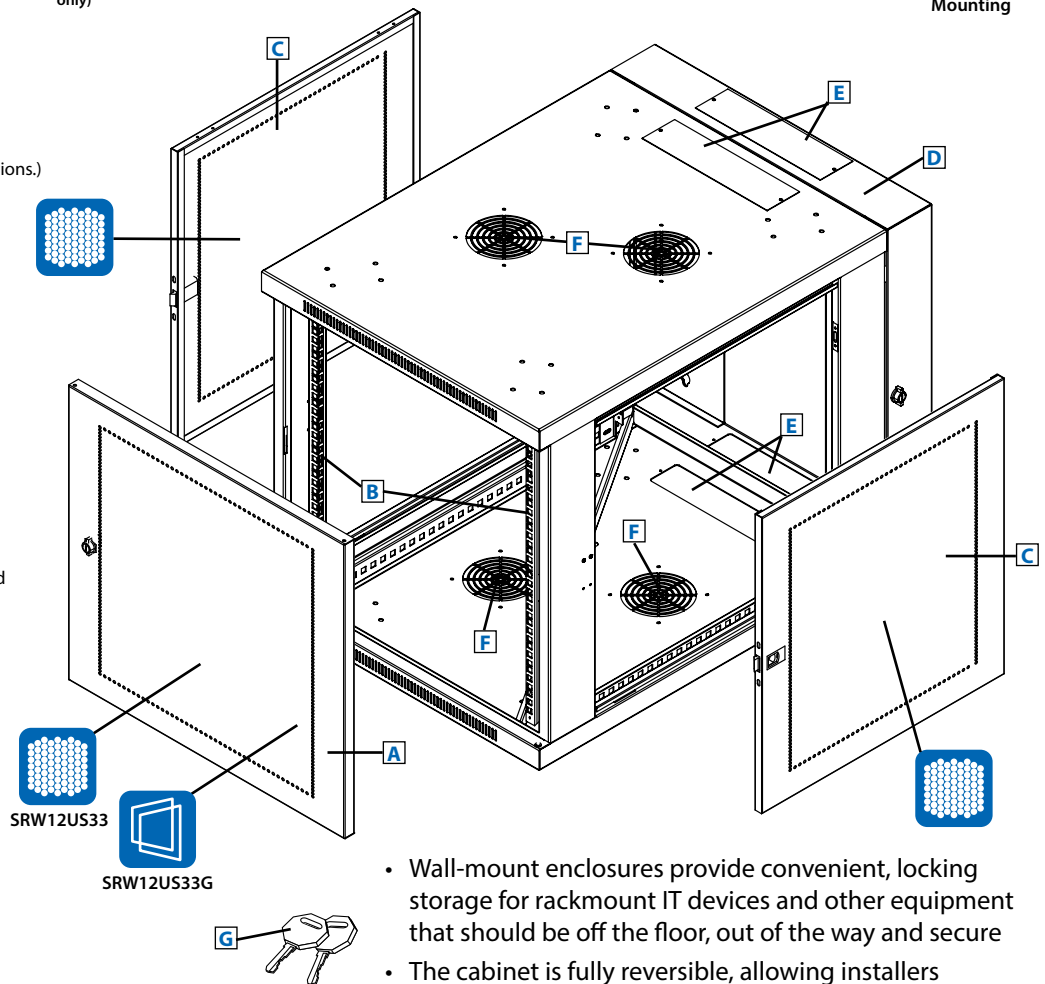

- Wall-mount enclosures provide convenient, locking storage for rackmount IT devices and other equipment that should be off the floor, out of the way and secure
- The cabinet is fully reversible, allowing installers to change door hinges from left to right by simply rotating the unit 180 degrees before mounting
- Hinged wall bracket allows cabinet to swing away from the wall for convenient access to equipment and cabling
- 33" depth accommodates standard-sized 1U servers and simplifies cable management

SEE NEXT PAGE FOR DETAILED UNIT MEASUREMENTS



1111 W. 35th Street
Chicago, IL 60609 USA
773.869.1234
www.tripplite.com

| Specifications | |
|---------------------------------|--|
| Models | SRW12US33 / SRW12US33G |
| Rack Spaces | 12U |
| Equipment Mounting Depth | Up to 32.5 in. (825.5 mm) |
| Load Rating* | 250 lb. (113.4 kg) |
| Unit Dimensions [H x W x D] | 25.18 x 23.62 x 33.5 in. (639.6 x 600 x 851 mm) |
| Shipping Dimensions [H x W x D] | 26.9 x 25.6 x 37.8 in. (683 x 650 x 960 mm) |
| Unit Weight | 100 lb. (45.36 kg) |
| Shipping Weight | 120 lb. (54.43 kg) |
| Standards | Tested to EIA-310-E, IEC 60297-3-100, NOM, RoHS and PCI-DSS standards; IP250 Protection Rating |

* The load rating includes the combined weight of the unit and installed equipment. The unit must be mounted to a stable surface with user-supplied anchors capable of bearing the full load.



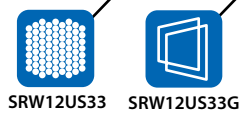
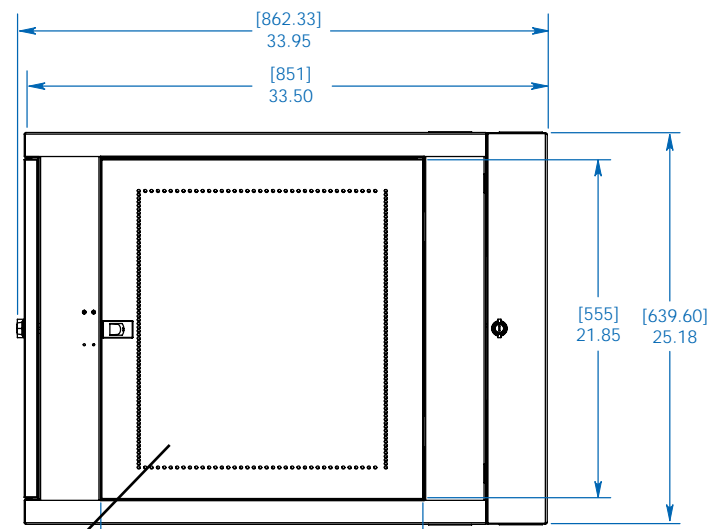
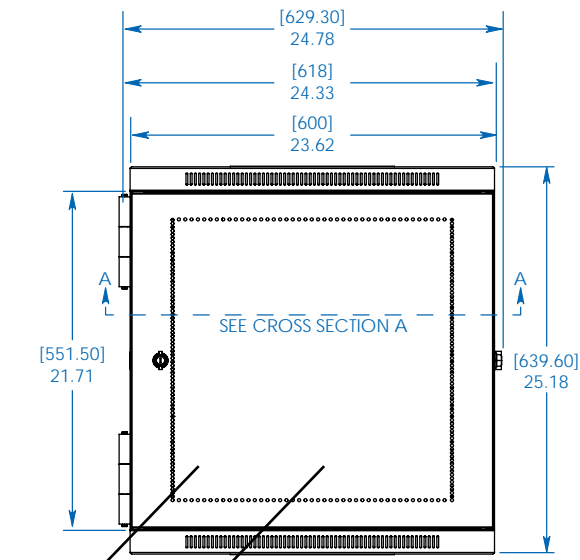

FRONT VIEW

SIDE VIEW

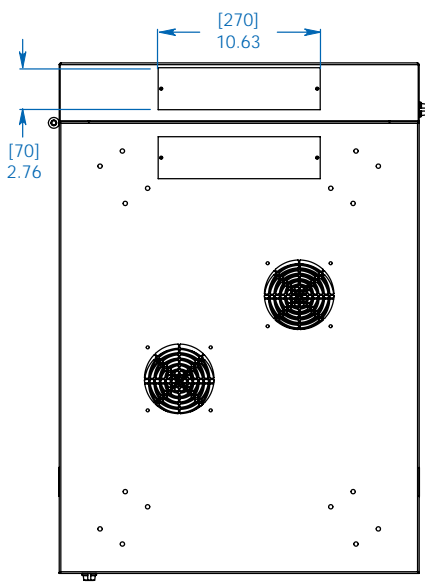
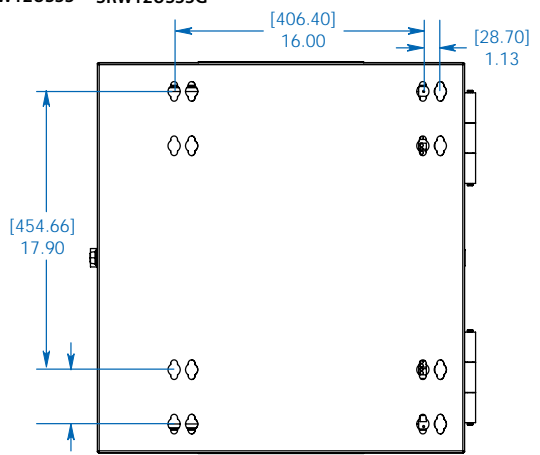

REAR VIEW

TOP/BOTTOM VIEW

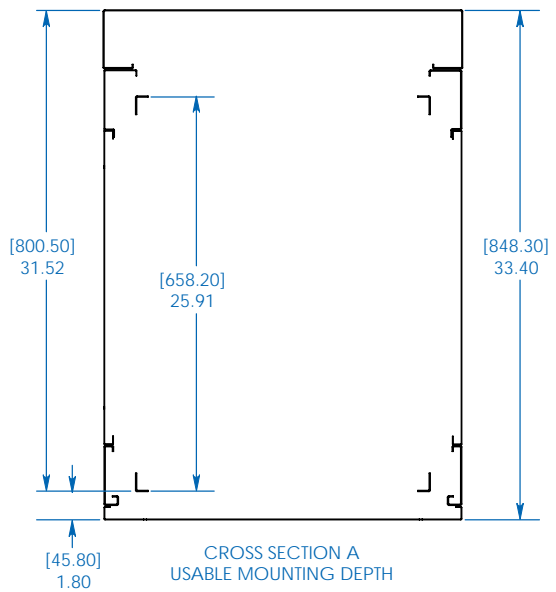

CROSS SECTION A
USABLE MOUNTING DEPTH

Dimensions: [mm] INCHES

Tripp Lite has a policy of continuous improvement. Specifications are subject to change without notice.



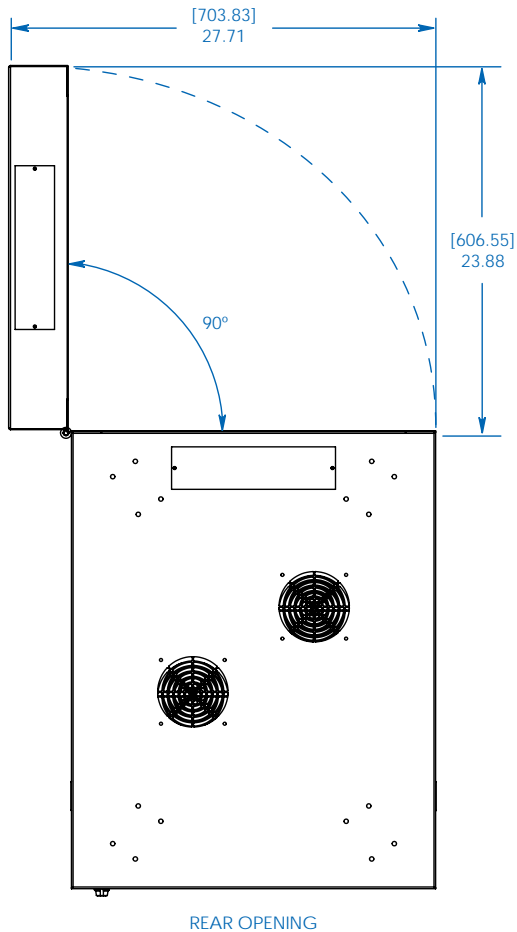
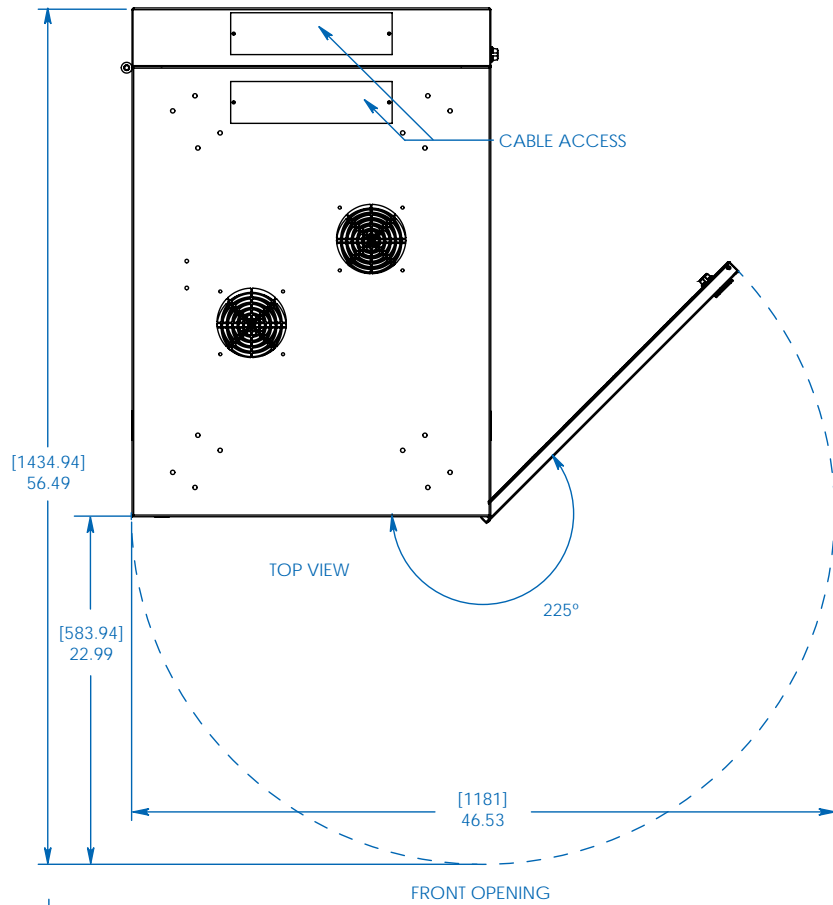

MODELS:
SRW12US33 /
SRW12US33G



1111 W. 35th Street
 Chicago, IL 60609 USA
 773.869.1234
 www.tripplite.com

Dimensions: [mm] INCHES

Tripp Lite has a policy of continuous improvement. Specifications are subject to change without notice.