

MODELS:

SRW12USDP / SRW12USDPG

SmartRack® Wall-Mount Deep Rack Enclosure Cabinets



12 Rack Units



200 lb.
Load Rating



Sturdy Steel
Construction



Locking Doors
& Side Panels



Clear Acrylic
Front Window
(SRW12USDPG only)



Hinged Wall
Bracket



Standard
19" Rack Width



Convenient
Cable Access



Adjustable
Mounting Rails

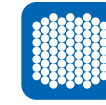

Ventilated for
Ample Airflow



Reversible
Cabinet

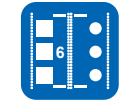

Square/
Threaded Hole
Mounting

- A** Front Door
(Lockable/Removable/Reversible.
SRW12USDP door is perforated;
SRW12USDPG door has a clear acrylic window.)
- B** Adjustable Mounting Rails (4)
(Support square and threaded hole mounting options.)
- C** Side Panels (2)
(Lockable/Removable)
- D** Cable Access Port Covers (4)
(Removable)
- E** Ventilation Fan Ports (4)
(Support optional SRFANWM fan kit.)
- F** Hinged Wall Bracket
- G** Keys (2)

Also Includes: Owner's manual, cabinet ground screw, pre-installed front door ground wire and rack-mount equipment mounting hardware (20 cage nuts, 20 M6 mounting screws, 20 #12-24 x 5/8" mounting screws, 20 nylon cup washers).

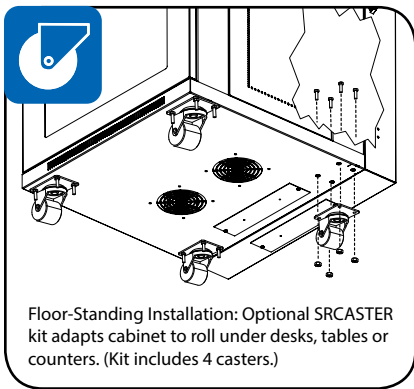

Floor-Standing Installation: Optional SRCASTER kit adapts cabinet to roll under desks, tables or counters. (Kit includes 4 casters.)

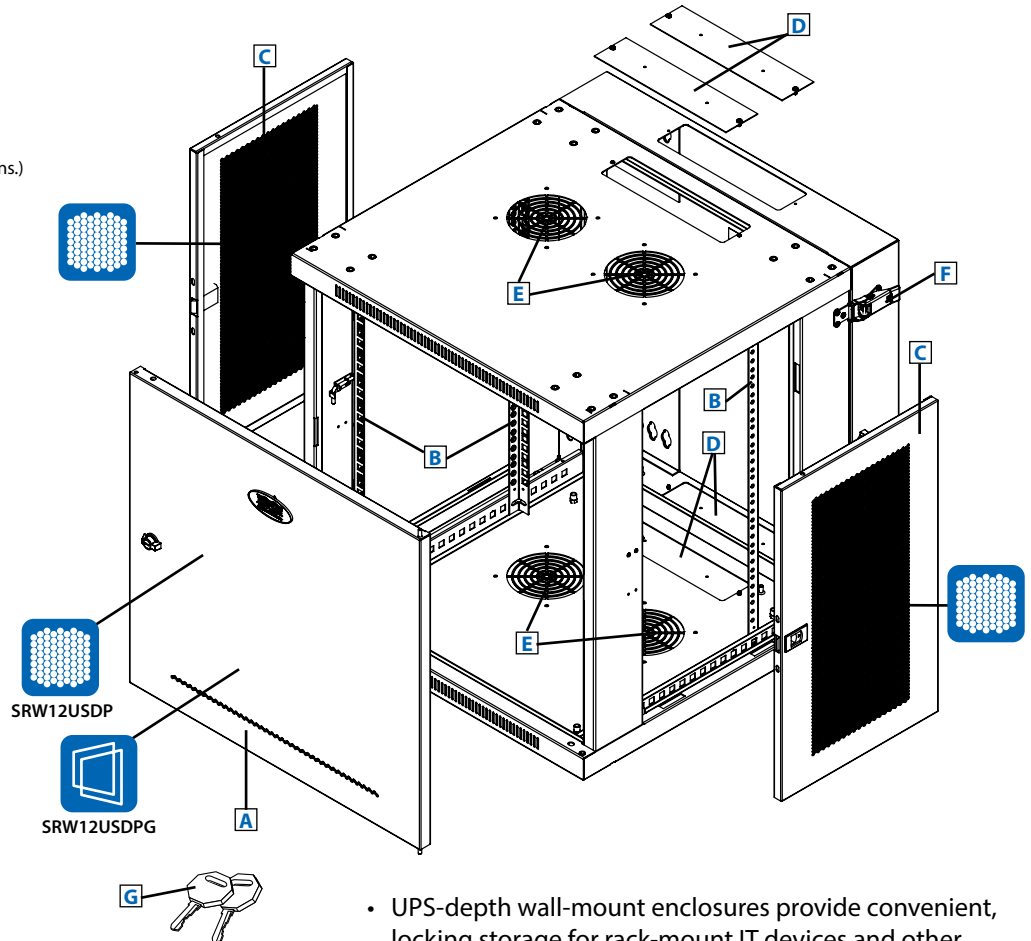

- UPS-depth wall-mount enclosures provide convenient, locking storage for rack-mount IT devices and other equipment that should be off the floor, out of the way and secure
- The cabinet is fully reversible, allowing installers to change door hinges from left to right by simply rotating the unit 180 degrees before mounting
- Hinged wall bracket allows cabinet to swing away from the wall for convenient access to equipment and cabling

SEE NEXT PAGE FOR DETAILED UNIT MEASUREMENTS



1111 W. 35th Street
Chicago, IL 60609 USA
773.869.1234
www.tripplite.com

Specifications

Model	SRW12USDP / SRW12USDPG
Rack Spaces	12U
Equipment Mounting Depth	Up to 24.5 in. / 622 mm
Load Rating*	200 lb./ 90.7 kg
Unit Dimensions (H x W x D)	25.06 x 23.63 x 25.5 in. / 636.5 x 600 x 648 mm
Shipping Dimension (H x W x D)	29.33 x 28.15 x 29.92 in. / 745 x 715 x 760 mm
Unit Weight	63.5 lb./ 28.8 kg (SRW12USDP) 64 lb./ 29 kg (SRW12USDPG)
Standards	Tested to UL/CSA 60950-1, IEC 60297-3-100, RoHS, NOM (Mexico), EIA/ECA-310-E, GOST; PCI Compliant, IP20 Protection Rating

* The load rating includes the combined weight of the unit and installed equipment. The unit must be mounted to a stable surface with user-supplied anchors capable of bearing the full load.



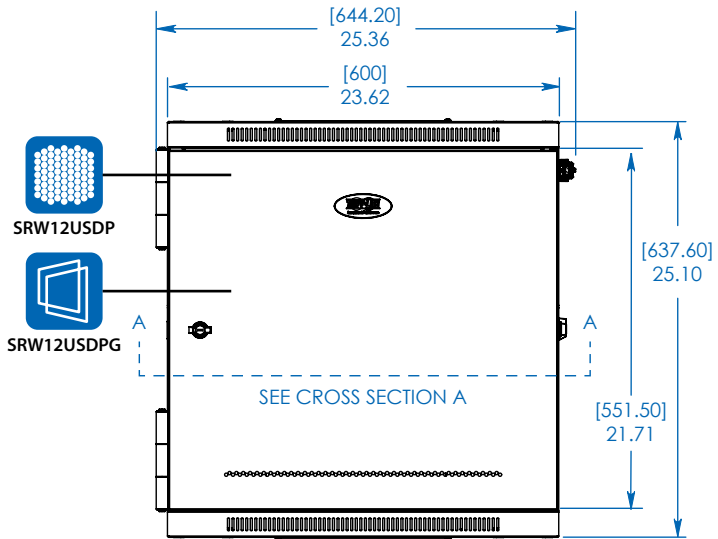

FRONT VIEW

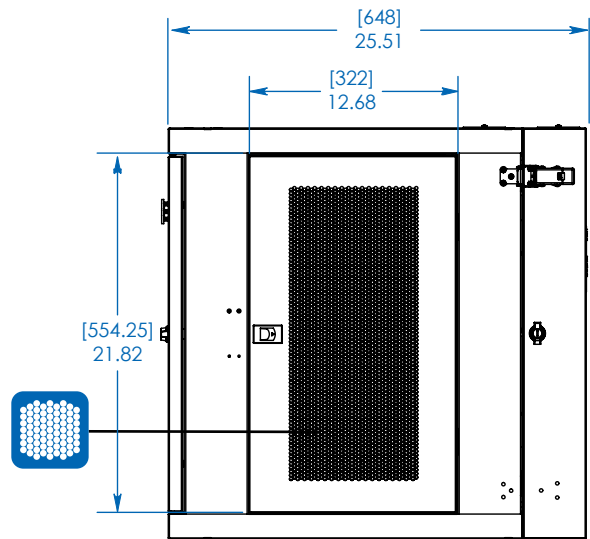

SIDE VIEW

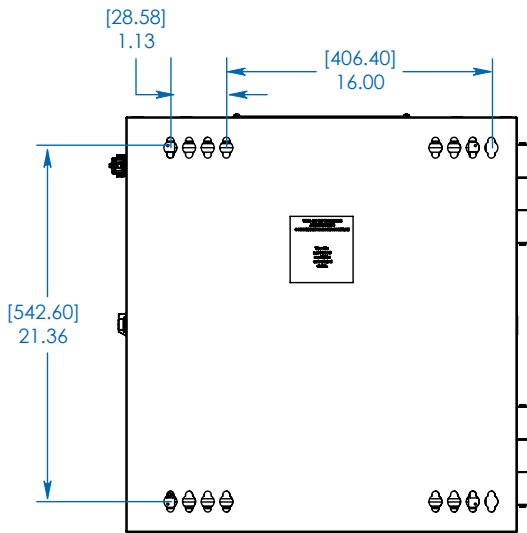

REAR VIEW

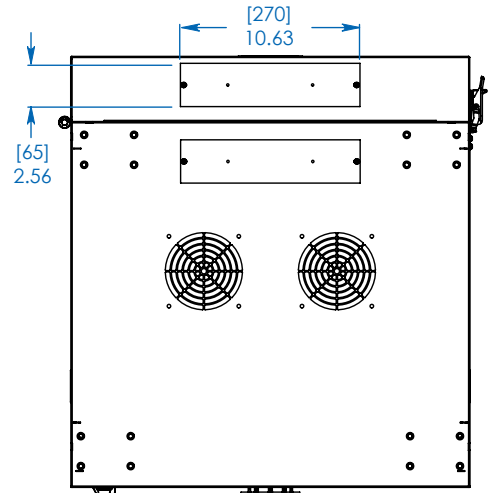

TOP/BOTTOM VIEW

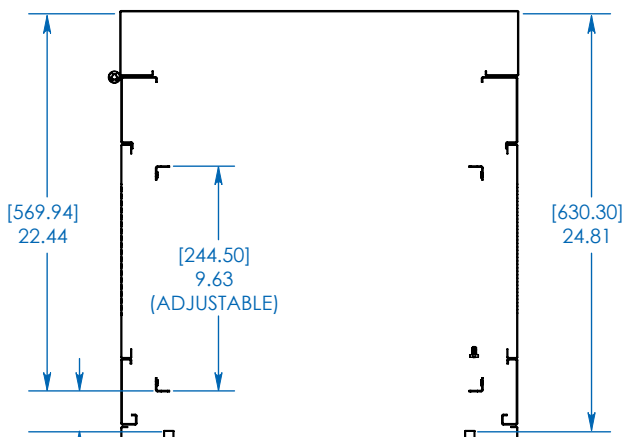

CROSS SECTION A
USABLE MOUNTING DEPTH

Dimensions: [mm] INCHES

Tripp Lite has a policy of continuous improvement. Specifications are subject to change without notice.



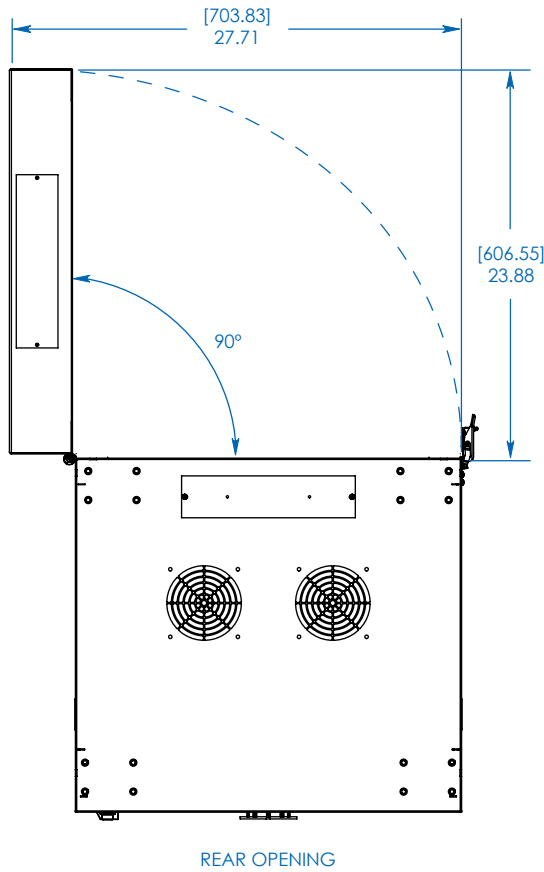
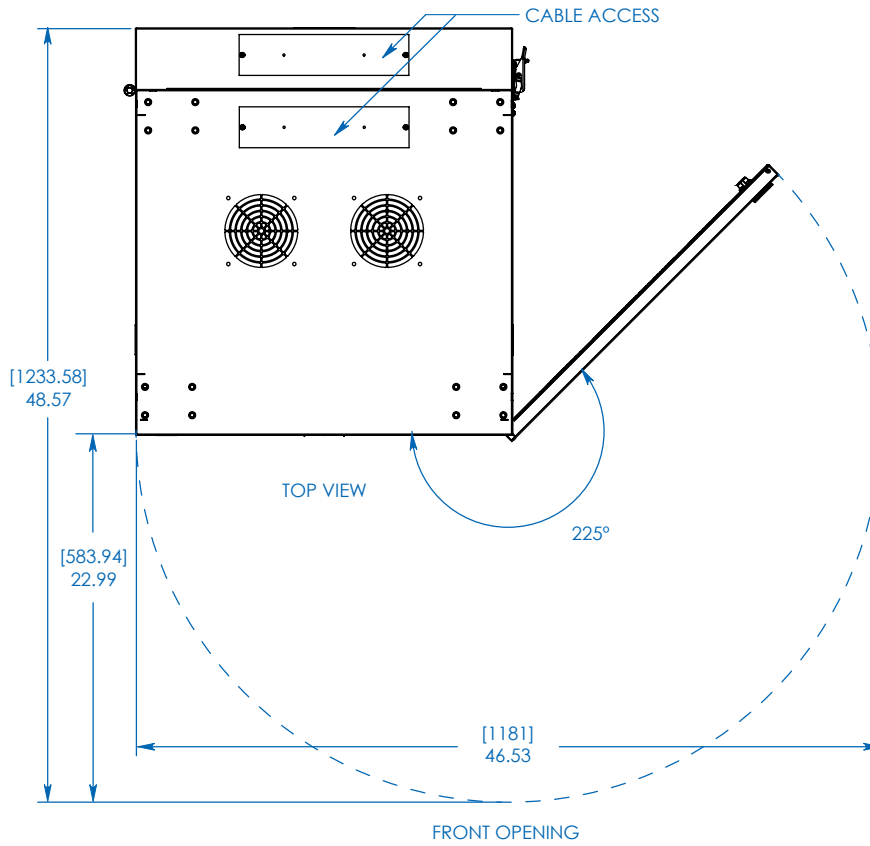

MODELS:
SRW12USDP /
SRW12USDPG



1111 W. 35th Street
 Chicago, IL 60609 USA
 773.869.1234
 www.tripplite.com

Dimensions: [mm] INCHES

Tripp Lite has a policy of continuous improvement. Specifications are subject to change without notice.